

SHEETERS LAMINOIRS LAMINADORAS



- > Struttura in acciaio verniciato (o in acciaio inox su richiesta)
- > Protezioni antinfortunistiche secondo la normativa CE
- > Regolazione precisa dello spessore della sfoglia mediante scala graduata
- > Raschiatori facilmente rimovibili
- > Tappeti a velocità variabile per ottenere uniformità nella sfoglia
- > Piani rialzabili per limitare al massimo l'ingombro quando la macchina non è in uso
- > Inversione del senso di laminazione dei tappeti mediante joystick e/o pedale.



- > *Painted steel structure (on request stainless steel is also possible)*
- > *Safety covers device in accordance with CE regulations*
- > *Precise regulation on thickness of sheet by a graded scale*
- > *Scrapers can be removed very easy*
- > *Variable speed between infeed and discharge belts assure regular dough sheet*
- > *Belts can be raised when the machine is not in use to obtain more free space*
- > *Reversal rolling belts by joystick and/or by pedal*



- > *Structure en acier verni (ou sur demand en acier inox)*
- > *Protections contre les accidents conformes aux lois CE.*
- > *Reglage precis du epaisseur du pate feuilletée par une echellee graduee*
- > *Racleur facilement amovible*
- > *Tapis avec vitesse variable pour assurer l'uniformite de la pate feuilletée*
- > *Table de travail remontable pour reduire l'encombrement*
- > *Inversion de laminage par joystick ou par pedale.*



- > *Estructura de acero barnizado (o a petición en acero inoxidable)*
- > *Protecciones contra infortunios de acuerdo con la regulación CE*
- > *Regulación precisa del espesor final de la hojaldre por medio de una escala graduada*
- > *Raspadores pueden ser muy fáciles quitado*
- > *Tapetes a velocidad variable aseguranos la precisión del espesor final de la hojaldre*
- > *Sistema de alzamiento de las mesas por obtener más espacio libre*
- > *Inversion de laminacion por medio de joytick y/o pedal*

SF500B

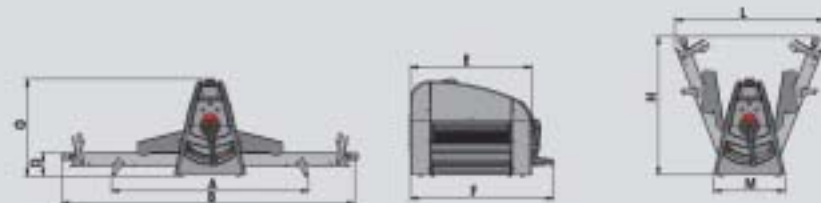

SF500

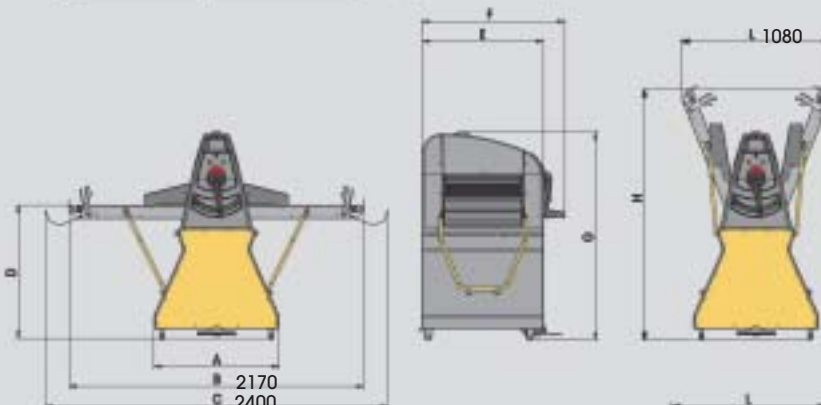

SF600

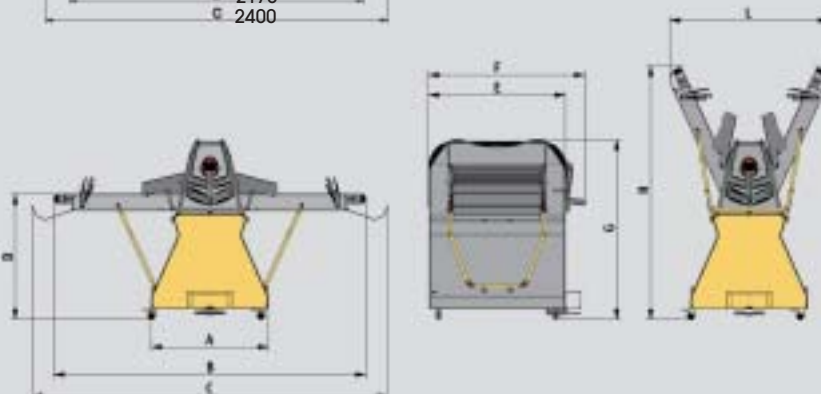
**DIMENSIONI/DIMENSIONS/DIMENSIONS/DIMENSIONES**

	A	B	C	D	E	F	G	H	L	M
SF500B-850	1250	1860	2110	150	770	910	620	880	950	455
SF500B-1000	1250	2160	2410	150	770	910	620	1030	1000	455
SF500-850	880	1860	2110	855	770	910	1335	1620	950	-
SF500-1000	880	2160	2410	855	770	910	1335	1760	1020	-
SF500-1200	880	2560	2810	855	770	910	1335	1920	1180	-
SF600-850	870	1860	2190	870	932	1065	1225	1619	960	-
SF600-1000	870	2160	2490	870	932	1065	1225	1757	1100	-
SF600-1200	870	2560	2890	870	932	1065	1225	1940	1250	-
SF600-1400	870	2960	3290	870	932	1065	1225	2123	1400	-

CARATTERISTICHE TECNICHE/TECHNICAL FEATURES/CARACTERISTIQUES TECHNIQUES/CARACTERISTICAS TECNICAS

CODICE MACCHINA/MACHINE CODE/ CODE MACHINE/ CODIGO MAQUINA	SF500B	SF500	SF600
TIPO/TYPE/TIPO	BENCH	A-FRAME	A-FRAME
LARGHEZZA TAPPETI/BELT WIDTH/LARGER TAPIS/ ANCHURA TAPETES	500 mm	500 mm	600 mm
LUNGHEZZA PIANI/ LENGHT BELTS/ LONGUEUR TAPIS/ LARGO TAPETES	850/1000	850/1000/1200	850/1000/1200/1400
VELOCITA' TAPPETO IN USCITA/EXIT BELT-VITESSE SPEED/ TAPIS-VELOCIDAD DE SORTIE/TAPETES EN SALIDA	50 cm/sec-30 m/min	50 cm/sec-30 m/min	50 cm/sec-30 m/min
APERTURA CILINDRI/ROLLER GAP/OUVERTURE CYLINDRES/APERTURA CILINDROS	0-35 mm	0-35 mm	0-40 mm
POTENZA MOTORE/MOTOR POWER/ PUISSANCE MOTOR/ POTENCIA MOTOR	0,55 kW	0,55 kW	0,75 mm
PESO/ WEIGHT/ POIDS/ PESO	140 Kg	170 Kg	245 Kg

Flomic

BAKERY AND PASTRY EQUIPMENT



SFOGLIATRICI



SF500



SF500

flamic



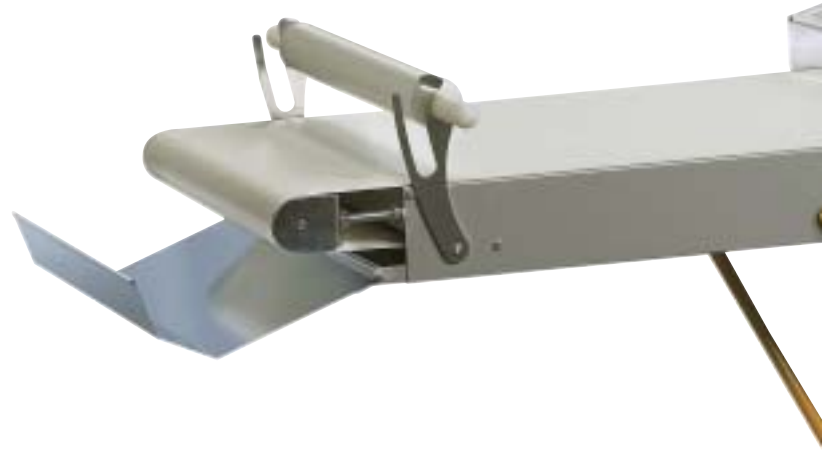

SF600

OB



SHEETERS LAMINOIRS LAMINADORAS



flamic